

Part Number **HSR-0025D** Contact Form A Switch Configuration SPST Rev. F

**World's Smallest and Most Sensitive Magnetically Operated Reed Switch**

| Features  | Advantages  |
|---|---|
| <ul style="list-style-type: none"> <li>• Hermetically sealed contacts</li> <li>• .035 height profile</li> <li>• .010 lead diameter</li> <li>• Oval body shape</li> <li>• Switch materials are Lead free and RoHs compliant</li> </ul> | <ul style="list-style-type: none"> <li>• Extended operations in extreme environments</li> <li>• Not ESD sensitive</li> <li>• World's smallest reed switch</li> <li>• World's most magnetically sensitive reed switch</li> <li>• Pick-and-place capable</li> <li>• Hi-Rel version available</li> </ul> |

**Electrical Specifications**

|             |                            |                 |             |
|-------------|----------------------------|-----------------|-------------|
| Power       |                            | Watts - maximum | 0.25        |
| Voltage     | Switching                  | VDC - maximum   | 30          |
|             | Breakdown                  | VDC - minimum   | 80          |
| Current     | Switching                  | Amp - maximum   | 0.01        |
|             | Carry                      | Amp - maximum   | 0.7         |
| Resistance  | Initial Contact Resistance | Ohm - maximum   | 0.75        |
|             | Insulation Resistance      | Ohm - minimum   | 1 E11       |
| Capacitance | Contact                    | pF - typical    | 0.7         |
| Temperature | Operating                  | °C              | -40 to +125 |
|             | Storage                    | °C              | -40 to +200 |

**Magnetic Specifications**

|                 |  |               |        |
|-----------------|--|---------------|--------|
| Pull - In Range |  | Ampere Turns  | 2-15   |
| Test Coil       |  | NARM RS-421-A | Coil I |

**Physical/Operational Specifications**

|                  |                  |                    |        |
|------------------|------------------|--------------------|--------|
| Capsule Volume   | Excluding Leads  | CC - nominal       | 0.0037 |
| Contact Material |                  |                    | Durel  |
| Operate Time     | Including Bounce | mSeconds - maximum | 0.30   |
| Release Time     | Including Bounce | mSeconds - maximum | 0.20   |

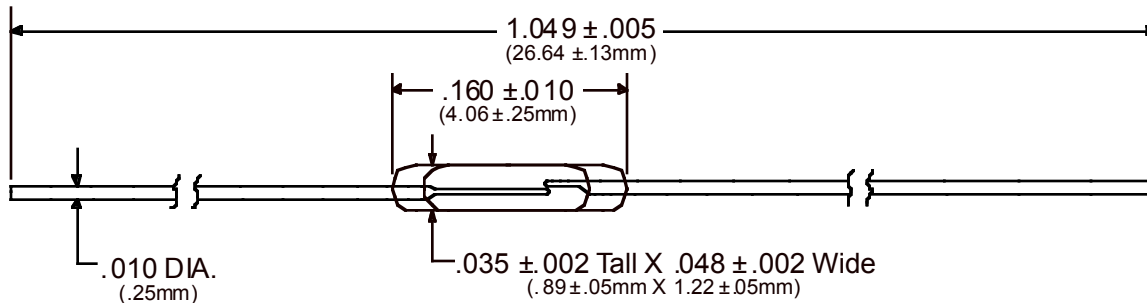

- Notes:
- (1) Specifications are not constant across entire magnetic range.
  - (2) Customer must exercise care in handling, mounting, lead forming, and cutting to prevent damage to glass capsule and/or switch sensitivity.
  - (3) For information or custom configurations about performance, mounting options or packaging, contact our Sales department.
  - (4) Information contained hereon is for informational purposes only and should not be deemed as accurate for a specific application. Consult factory for specific application information and/or latest revision.